

1940

TECHNICAL INFORMATION

BULLETIN NO. 142.

(TYPE)

5-VALVE DUAL WAVE RECEIVERS.

MODEL G425/G520

RECEIVER

COLLIER & BEALE LTD.

WELLINGTON

TECHNICAL DESCRIPTION AND ADJUSTMENT PROCEDURE

OF 5-VALVE DUAL-WAVE RECEIVERS

MODELS G-425 AND C-520.

Model G-425/C-520 receiver is of the Superheterodyne type and employs a total of 5-valves used in the following arrangement:-

1	-	type 6A7	Mixer oscillator
1	-	" 6D6	Intermediate frequency amplifier (465-Kc/s.)
1	-	" 6B7	Diode rectifier and 1st audio amplifier
1	-	" 42	Power amplifier
1	-	" 80	Power supply rectifier

The circuit embodied in this receiver is conventional in every respect. The 2 frequency ranges being covered by separate coil assemblies, the range desired being brought into action by a panel operated switch.

Adjustment of the receiver, if ever required, should be undertaken along orthodox lines; the following procedure - which should be used in conjunction with schematic drawings Nos. 299 and 300 - is recommended.

Intermediate Frequency Amplifier. The intermediate frequency used in model G-425/C-520, is 465-Kc/s., both transformers being adjusted for maximum output, and under no circumstances should a "staggered" adjustment be used, as the "gain" of the whole receiver will be materially affected. Adjustment of the 2 transformers should be undertaken by first aligning the diode transformer alone, this being accomplished by clipping the signal generator plate on to the grid of the frequency amplifier tube (6D6) and adjusting for maximum output. The generator unit should then be transferred to the grid of the mixer tube (6A7) and the first transformer treated in a similar manner. In this latter adjustment it is desirable to make certain that the wave-band switch is in the "broadcast" position, otherwise the comparatively low impedance of the short-wave tuned circuits at this test frequency will place the equivalent of a short-circuit across the generator terminals and so make the obtaining of an adequate test voltage difficult. An alternative arrangement - to avoid any possibility of loss in the detector input circuits - is to entirely remove the grid lead from this valve, and to complete the grid circuit temporarily with a fixed resistor of approximately 50,000-ohms resistance.

Signal Frequency Circuits Alignment. Adjustment of the signal frequency circuits, although not difficult, should be undertaken with a fair amount of care, particularly in the setting of the oscillator trimmer condensers, and, in no case, unless the performance of the receiver is in question, should any attempt be made to disturb the factory adjustment, regardless of minor errors in dial readings. In all cases, the broadcast band should be treated first; the order of adjustment is as follows:-

With an accurate signal generator set at some convenient high frequency, say 1,500-Kc/s. or 1,600-Kc/s., and with the gang condenser set at the correct position as indicated by the dial scale, the oscillator trimmer should be adjusted for maximum output. With this adjustment made, both the mixer and pre-selector

trimmers may then be adjusted, it being noted that the pre-selector trimmer is located on top of the gang tuning condenser, and the mixer trimmer- designated T-4- underneath the chassis adjacent to the pre-selector coil unit. Neither of these two (2) latter adjustments is critical nor difficult to perform, and very rarely unless the receiver has been tampered with will any major variation be required to be made.

With these adjustments satisfactorily made, the receiver should be aligned or "padded" at the low frequency end of the band, this adjustment taking place at approximately 600-Kc/s. The most satisfactory way of adjusting the padding condenser is to use a highly damped signal generator, to avoid the necessity of constantly "rocking" the tuning mechanism, to ensure the optimum adjustment that provides maximum output. The most suitable highly damped source is generally available in the variety of electrical disturbances that constitute the usual background of a radio receiver when connected to an antenna. The receiver, therefore, should preferably be tuned to a frequency of 600-Kc/s., making sure that no station carrier wave is present, and the padding condenser adjusted for maximum noise output. After satisfactory adjustment of the padding condenser, it is wise again to re-check the high frequency oscillator trimmer condenser, this latter adjustment only being necessitated if a considerable movement of the padding condenser has taken place.

The adjustment of the short-wave band should be undertaken in an identical manner to that described above, the only requirement being the exercise of greater care in the adjustment of the oscillator trimmer condenser, which in this case, will be found to be quite critical. The same remarks in regard to the avoidance of altering trimmer adjustment, if the performance of the receiver is satisfactory, apply in this band as well, and in the event of dial readings being appreciably out, movement of the pointer should be suspected and adjustment made accordingly. In certain cases unequal stretching of the dial operating cord can produce fair discrepancies in dial reading, and in such cases, the remedy is quite simple and necessitates only the repositioning of the cursor on the dial operating cord.

As an aid in servicing the receiver in the event of failure in any of the components fitted, a component schedule is appended which is to be used in conjunction with the schematic diagrams attached.

COLLIER & BEALE LIMITED,
66 GHUZNEE STREET,
WELLINGTON, C.2.
16th September, 1940.

COMPONENT SCHEDULE FOR MODEL G-425/C-520

RECEIVER.

CONDENSERS:

C-1	.01-mfd	Audio coupling
2	8 ")	
3	8 ")	Power supply filter condensers
4	.25 "	Audio Plate filter
5	.1 "	Screen R.F. by-pass
6	.1 "	Cathode " "
7	.1 "	Screen by-pass (1st A.F. stage)
8	.1 "	A.F. bias filter
9	.1 "	H.T. R.F. by-pass
10	.05 "	A.V.C. filter
11	.01 "	Oscillator R.F. by-pass
12	.01 "	Audio coupling
13	.01 "	" "
14	.004 "	Fixed padding (.S.W.band)
15	.004 "	Audio Filter
16	.00025 "	Tone Control
17	.0001 "	R.F. plate filter
18	.0001 "	Oscillator grid
19	.0001 "	Diode load by-pass
20	2,000-mmfd	Variable padding (S.W. Band)
21	550 "	" " (B.C. ")
22	15 "	H.F. coupling
T-1)	
2)	
3)	H.F. alignment trimming capacitors.
4)	
5)	

RESISTORS:

R-1	1-meg	Screen feed (1st A.F. stage)
2	1 "	A.V.C. filter
3	.5 "	Audio bias potential divider
4	.5 "	Audio bias filter
5	.5 "	Diode load
6	10 "	Audio grid leak
7	.25 "	Plate load (1st A.F. stage)
8	.1 "	Plate feed
+9	75,000-ohm	Audio bias potential divider
10	50,000 "	Oscillator grid leak
11	25,000 "	Screen feed
12	10,000 "	Oscillator feed
13	300 "	Cathode bias
14	.5-meg	Volume control
15	.5 "	" "

COLLIER & BEALE LIMITED,
66 GHUZNEE STREET, W'GTON, C.2.
16th September, 1940

+ R9 changed in Model 521G
and 521-G to 150,000-ohm.

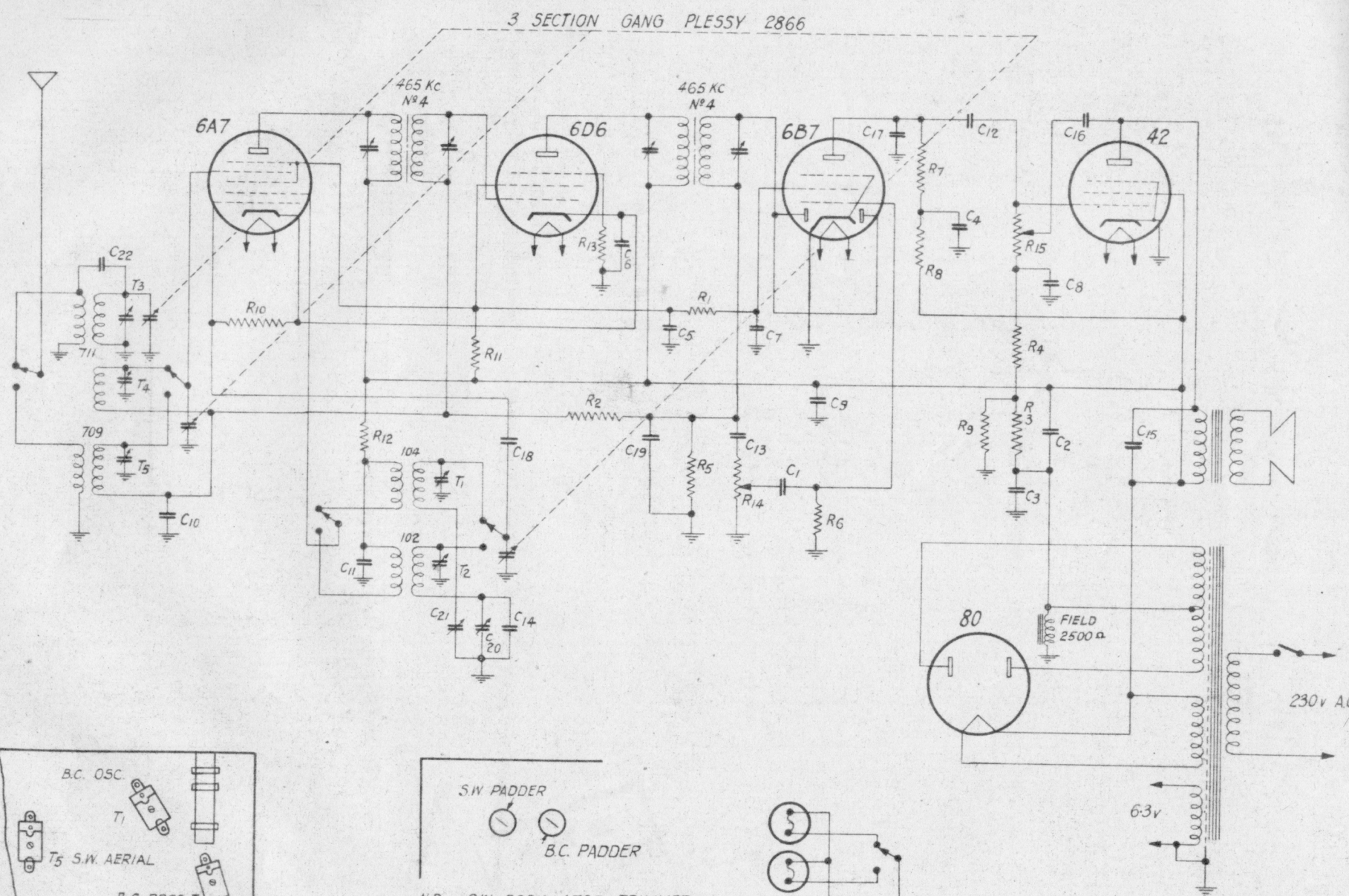

3 SECTION GANG PLESSY 2866

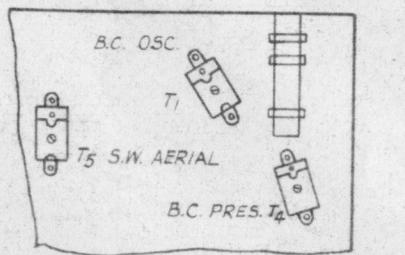

SECTION OF CHASSIS SHOWING TRIMMERS MOUNTED UNDERNEATH

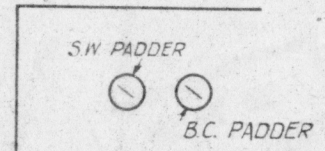

N.B. S.W. OSCILLATOR TRIMMER (T₂) MOUNTED ON SIDE OF COIL CAN. B.C. AERIAL TRIMMER (T₃) ON TOP OF GANG

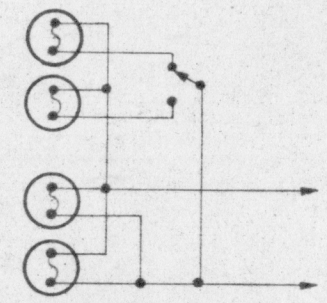

CHASSIS LAYOUT OF G425 & C520

