

G. A. WOOLLER & CO. LTD.



PHONE 43-727
P.O. BOX 2167
AUCKLAND

TELEGRAPHIC AND
CABLE ADDRESS
"FIVESTAR"

4th FLOOR, CHANCERY CHAMBERS
CHANCERY STREET

AUCKLAND, N.Z.

date ?

MODEL 6P1 PORTABLE RADIO RECEIVER

IMPORTANT SERVICE INSTRUCTION

In certain districts it would seem that "off peak" AC line Voltages may rise appreciably higher than the 230 volt nominal. Should this be the case there is a danger of burning out the dry rectifiers in Model 6P1. Tests have shown that where Line Voltage rises to 240/250 volts the current drawn by the receiver will also rise causing excessive heat in the dry rectifiers with resultant breakdown after a short period of operation.

In order to ensure that Model 6P1 Receiver will not be affected under such high line voltage conditions it is recommended that the following modification be carried out:

On opening the back of the receiver, removing the battery and the cardboard cover surrounding the chassis (which is there for the purpose of preventing the chassis from being touched when operating on AC/DC) the two Dry Rectifiers will be noted on the top lefthand portion of the chassis, as will two 220 Ohm Resistors in parallel, between the rectifiers and the 1500 Ohm Wire Wound Resistor. It is recommended that these two 220 Ohm Resistors in parallel be lifted from their point of attachment to the 1500 Ohm Wire Wound resistor and that two more 220 Ohm 1 watt resistors in parallel be inserted to make a total resistance of 220 Ohms between the rectifiers and the Wire Wound resistor. In other words there will be four resistors in series parallel.

This modification will reduce the AC voltage across the rectifiers and also slightly reduce the H.T. voltage applied to the plates of the valves in the receiver but there will be no deterioration in performance by virtue of this modification.

In recent tests which have been conducted it was noted that line voltage varied from 190 volts to 240 volts between peak load and off load conditions. It is therefore, recommended that wherever dealers suspect voltage peaks in excess of 230 may occur that the above described modification be carried out.

It will be noted that the modification can be easily carried out by any dealer without removing the set from the cabinet and, if required, resistors will be supplied by the factory for this purpose at no charge.

Should a set be brought into a dealer with the rectifiers burned out it is recommended that the procedure described in the attached sheet headed "Instructions for replacing rectifier assembly" be carried out.

The factory will stand behind all Model 6P1's and should any rectifiers have been burned out due to the causes described above the factory will supply a new rectifier assembly free of charge.

INSTRUCTIONS FOR REPLACING RECTIFIER ASSEMBLY

MODEL 6P1

Should it become necessary to replace rectifiers on Portable Model 6P1 we have devised a method by which this may be done without removing the chassis from the cabinet, thus saving Servicemen's valuable time and avoiding possible risk to the paint work of the cabinet during disassembly and subsequent reassembly.

The procedure is as follows:

1. Obtain from the Factory a new rectifier assembly complete with the following items:

- (a) 2 ^{selenium (See Tel. Call)} Dry Rectifier Units type RM3 *RM2?*
- (b) 1 mounting bracket
- (c) 1 $\frac{3}{8}$ " x No. 8 Self Tapper
- (d) 4 220 Ohm 1 watt resistors

NOTE: This assembly will come to you complete ready for substitution.

2. Remove the defective rectifier stack by carefully undoing the screw through the centre of ~~the rectifier stack~~ allowing the nut on the inside of the chassis to fall loose. This can be shaken out later. Also remove the 2 only 1 watt 220 Ohm Carbon Resistors and discard with the defective rectifiers.

3. Remove the .01 condenser connected between the two outside lugs of the defective rectifier stack and solder in same position on replacement stack.

4. Remove the bolt holding the replacement rectifier stack to the bracket supplied allowing the bracket to be mounted by means of the self-tapper supplied, in the hole from which the defective rectifier stack has been removed.

5. Having mounted the bracket reassemble the new rectifier stack on the bracket with the bracket between the two rectifiers and with the condenser pointing to the rear of the cabinet.

6. Connect the free end of the series parallel arrangement of 4 only 220 Ohm 1 watt carbon resistors to the end of the wire-wound resistor from which the two carbon resistors in parallel were originally detached when removing the defective rectifier stack.

IMPORTANT: Please note that the positive end of the rectifier stack must go to the side nearest to the wire wound resistor to which it must be connected through the series parallel carbon resistors, the total resistance of which will be 220 ohms.

7. Lengthen the lead to be soldered to the negative end of the ~~resistor~~ ^{rectifier} stack by approx. 1" and connect.

NOTE: This lead comes through a rubber grommet at the top left hand rear corner of the chassis.

AKRAD RADIO CORPORATION LTD.

WAIHI

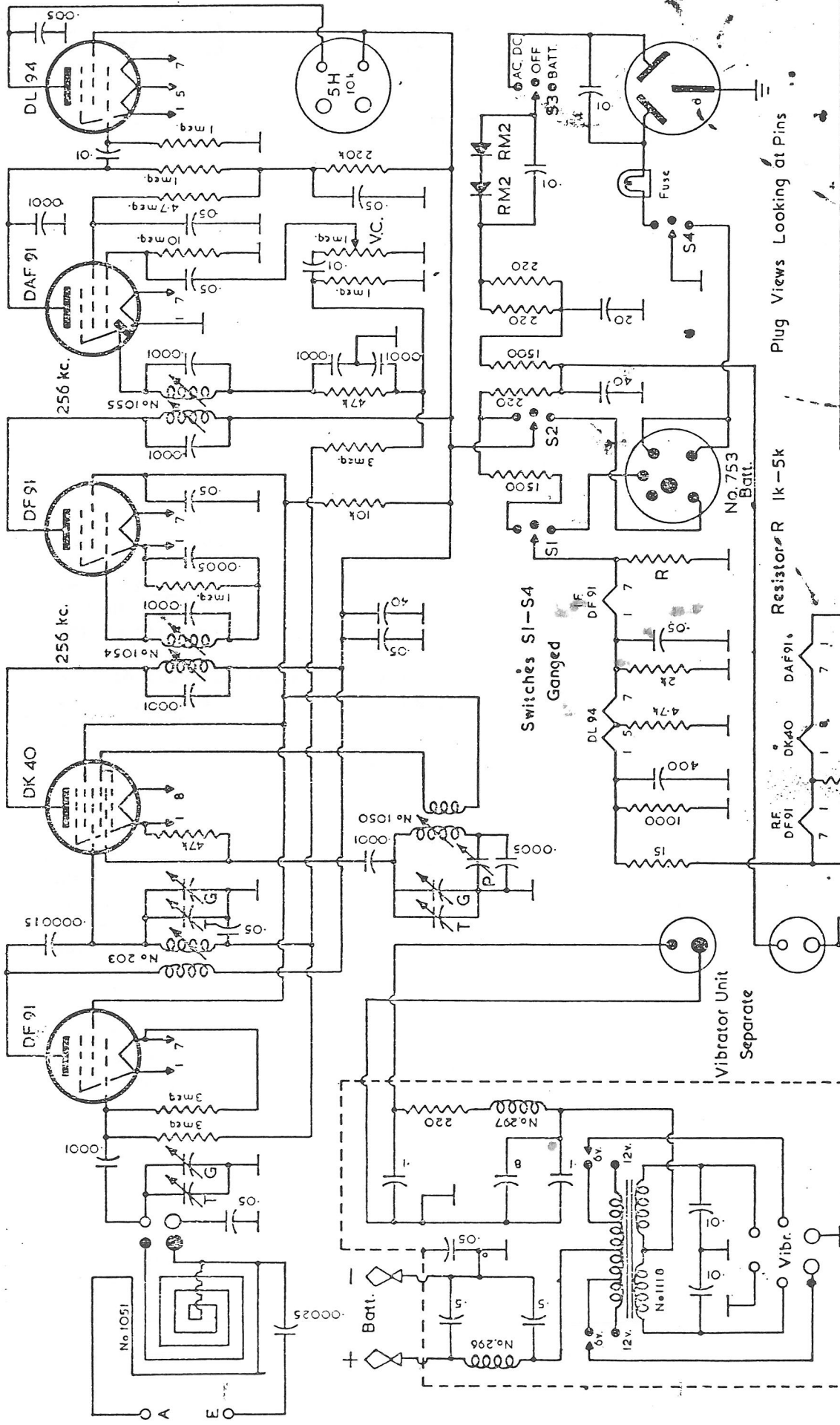

Plug Views Looking at Pins

Resistor R 1k-5k

Vibrator Unit Separate

MODEL 6PI / SCHEMATIC

Drawn	E. W. S.	16/11/50
Traced	E. W. S.	17/11/50
Checked	G. J. C.	21/11/50

DRG. NO. 1124
AKRAD RADIO CORP. LTD.
WAIHI

⊥ = Chassis
⊥ = Case

Capacities shown in Microfarads
Resistances shown in Ohms