

PHILIPS RADIOPLAYER: MODEL LZ546UB

5-Valve Superheterodyne
 Supply—230 volts A.C. or D.C.
 or 2 x 67.5 volt Type 467 Eveready Batteries
 1 x 3 volt Type 701 Eveready Battery
 Wave Range 535–1600 Kc/s
 Intermediate Frequency 455 Kc/s

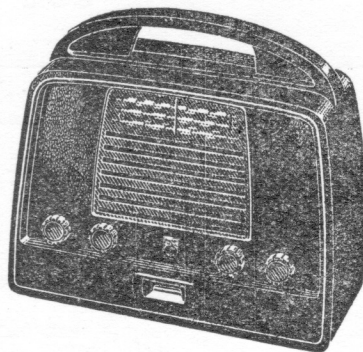

REMOVAL FROM THE CABINET

Remove the mains plug from the supply.

Remove the thumb screw holding the cover of the battery compartment under the receiver, slide the cover back and take out the batteries. Loosen the four screws holding the moulded back. Note that these screws are retained in the back by special washers. When the back screws are released the back may be removed from the connecting socket. This socket may be moved in its mounting so that when replacing the back, plug the back into the socket making certain that the long pin is inserted in the centre socket hole. Then line the back up to the cabinet before attempting to tighten any of the back screws. Pull off the four knobs, noting that the power supply selector knob and tone control knob have white indicator dots on them. Prise the bottom edges of the perspex grille dial scale out from the cabinet and remove.

From the back of the chassis remove three screws holding the battery mounting plate and slide the plate out. Unsolder the speaker wires from the lugs on the output transformer. Remove the two chassis mounting screws and the chassis will slide out of the cabinet. To replace the chassis in the cabinet, slide the chassis partly into the cabinet and with a screwdriver lift the end of the pointer through the slot in the front of the cabinet. Push the chassis right into position and see that the pointer comes through the slot into its correct position. Replace the chassis mounting screws and tighten. Replace the dial scale by placing the top tongues into the slots and pushing the bottom lugs into position. Replace the knobs. Solder the speaker wires to the output transformer. Replace the battery mounting plate, and securely tighten the three screws. Make sure that the front of the plate fits into the grooves provided in the cabinet. Plug in the back moulding, adjust the position and tighten the four screws. Replace the batteries, tuck away the power cord, and replace the bottom.

ALIGNMENT OF THE RECEIVER

For the alignment of the receiver, the chassis should be mounted in the cabinet, without the moulded back. The receiver should be aligned on mains supply and as the power supply is direct from the mains a double wound one to one transformer should be used. Be sure that the chassis is not connected to the phase of the mains supply. Plug the receiver into the receptacle of the transformer, switch the supply selector switch to mains position (left-hand knob) and allow the receiver to warm up for a few minutes. Turn the volume control to the maximum position and the tuning condenser to maximum capacity.

Set the pointer to the point below 550 Kc/s where the frame line of the dial meets the calibration line. Disconnect the grid coupling condenser C12 from the control grid of the DK40 valve and connect the signal generator through a 0.01 mfd condenser to the grid. Apply a signal of 455 Kc/s modulated 30%, and adjust the intermediate frequency filters for maximum output by means of the adjusting slugs on the top of the coil cans.

1. Diode coil
2. DF91 plate coil
3. DK40 plate coil
4. DF91 grid coil

Repeat the above until maximum output is obtained. Disconnect the 0.01 mfd condenser from the control grid of the DK40 and reconnect C12.

Connect the 0.01 mfd condenser to the junction of C8 and R4 (control grid of DF91—signal amplifier) and apply a signal of 455 Kc/s modulated 30%. Adjust L3 for minimum output by means of the slug on top of the coil.

Turn the pointer to the 600 Kc/s position on the dial, and apply a signal of 600 Kc/s modulated 30% to the control grid of the DF91 signal amplifier. Adjust the oscillator inductance T1 by means of the slug in the top of the coil can, until the signal is tuned in.

Turn the pointer to the 1500 Kc/s position on the dial and apply a signal of 1500 Kc/s modulated 30% to the control grid of the DF91 signal amplifier. Adjust the oscillator trimmer on top of the small section of the tuning condenser until the signal is tuned in. Repeat for 600 and 1500 Kc/s until the calibration of these two points is correct.

Disconnect the 0.01 mfd signal generator coupling condenser from the control grid of the DF91 signal amplifier.

Plug the connecting plug on the moulded back into the socket on the receiver, and connect the signal generator by means of a standard dummy aerial to the aerial and earth terminals of the receiver.

Do not engage the back mounting screws, and leave a slight gap between the top of the cabinet and the back moulding. Through this gap, a long thin screwdriver can be inserted, to engage the aerial trimmer on top of the tuning condenser. From the signal generator, apply a signal of 1500 Kc/s to the aerial terminal, and adjust the aerial trimmer C3 for maximum output. For the final adjustment of C3 the batteries and bottom cover should be in place. When all adjustments are complete seal all slugs and trimmers.

BATTERY INFORMATION

The high tension supply for this receiver when operating from the internal batteries is derived from two Eveready type 467 layer built batteries. The high tension drain is 12 milliamps + or - 10%. Under normal conditions the battery life should be as follows:—

| Battery Volts | | Discharge Rate | |
|------------------|-----------|----------------|-----------|
| | | 2 hrs/day | 3 hrs/day |
| Fully discharged | 45 } type | 24 hrs | 15 hrs |
| | 36 } 467 | 30 " | 20 " |
| Fully discharged | 2½ } type | 16 " | 11 " |
| | 2 } 701 | 20 " | 15 " |

Type 701 cycle battery (2 cell) supplies the filaments, the current drain being 150 milliamps.

In the "charge" position of the supply selector switch a small charge current (6 milliamps approximately) is supplied to the high tension batteries. Provided that fresh batteries are used and are charged as soon as possible after use, the life of the type 467 batteries may be increased to 2-2½ times the normal life.

PHILIPS RADIOPLAYER: MODEL LZ546UB

With the Compliments of...

RADIO WHOLESALERS LTD.

P.O. Box 527

INVERCARGILL

CONDENSERS

- C1 12-460 mmid } gang condenser
- C2 10-193 mmid } compression trimmer
- C3 3-30 mmid } compression trimmer
- C4 3-30 mmid } compression trimmer
- C5 .01 mfd 1500v. paper
- C6 .01 mfd 750v. paper
- C7 400 mmid mica
- C8 100 mfd ceramic
- C9 .01 mfd 500v. paper
- C10 .1 mfd 100v. paper
- C11 .27 mmid ceramic
- C12 150 mmid ceramic
- C13 100 mmid ceramic
- C14 .02 mfd 500v. paper
- C15 110 mmid ceramic I.F.
- C16 185 mmid ceramic I.F.
- C17 .01 mfd 350v. paper
- C18 .01 mfd 500v. paper
- C19 110 mmid ceramic I.F.
- C20 185 mmid ceramic I.F.
- C21 100 mmid ceramic
- C22 .01 mfd 500v. paper
- C23 .25 mfd 150v. paper
- C24 .001 mfd 750v. paper
- C25 .005 mfd 750v. paper
- C26 .005 mfd 750v. paper
- C27 100 mfd 10v. electrolytic
- C28 100 mfd 10v. "
- C29 40 mfd 350v. } electrolytic
- C30 40 mfd 350v. } electrolytic
- C31 20 mfd 350v. }
- C32 .05 mfd 350v. paper

RESISTORS

- R1 150 ohms 4w. wire wound
- R2 1800 ohms 10w. wire wound
- R3 27k 1w. carbon
- R4 1 meg. 1/2w. carbon
- R5 1500 ohms 1/2w. 5% carbon
- R6 5000 ohms 10w. w.w. adjustable
- R7 33k 1/2w. carbon
- R8 15k 1/2w. carbon
- R9 27 meg. 1/2w. carbon
- R10 30k 1/2w. carbon
- R11 1500 ohms 1/2w. carbon
- R12 1500 ohms 1/2w. carbon
- R13 2.2 meg. 1/2w. carbon
- R14 4.7 meg. 1/2w. "
- R15 4.7 meg. 1/2w. "
- R16 4.7 meg. 1/2w. "
- R17 .5 meg. volume control
- R18 47k 1/2w. carbon
- R19 10 meg. 1/2w. carbon
- R20 680 ohms 1/2w. or 5% 1/2w. carbon
- R21 4.7 meg. 1/2w. carbon
- R22 1 meg. 1/2w. carbon
- R23 3300 ohms 1/2w. carbon
- R24 560 ohms 1/2w. carbon
- R25 1 meg. 1/2w. carbon
- R26 470 ohms 1/2w. carbon
- R27 1000 ohms 1/2w. or 5% 1/2w. carbon
- R28 1 meg. 1/2w. carbon

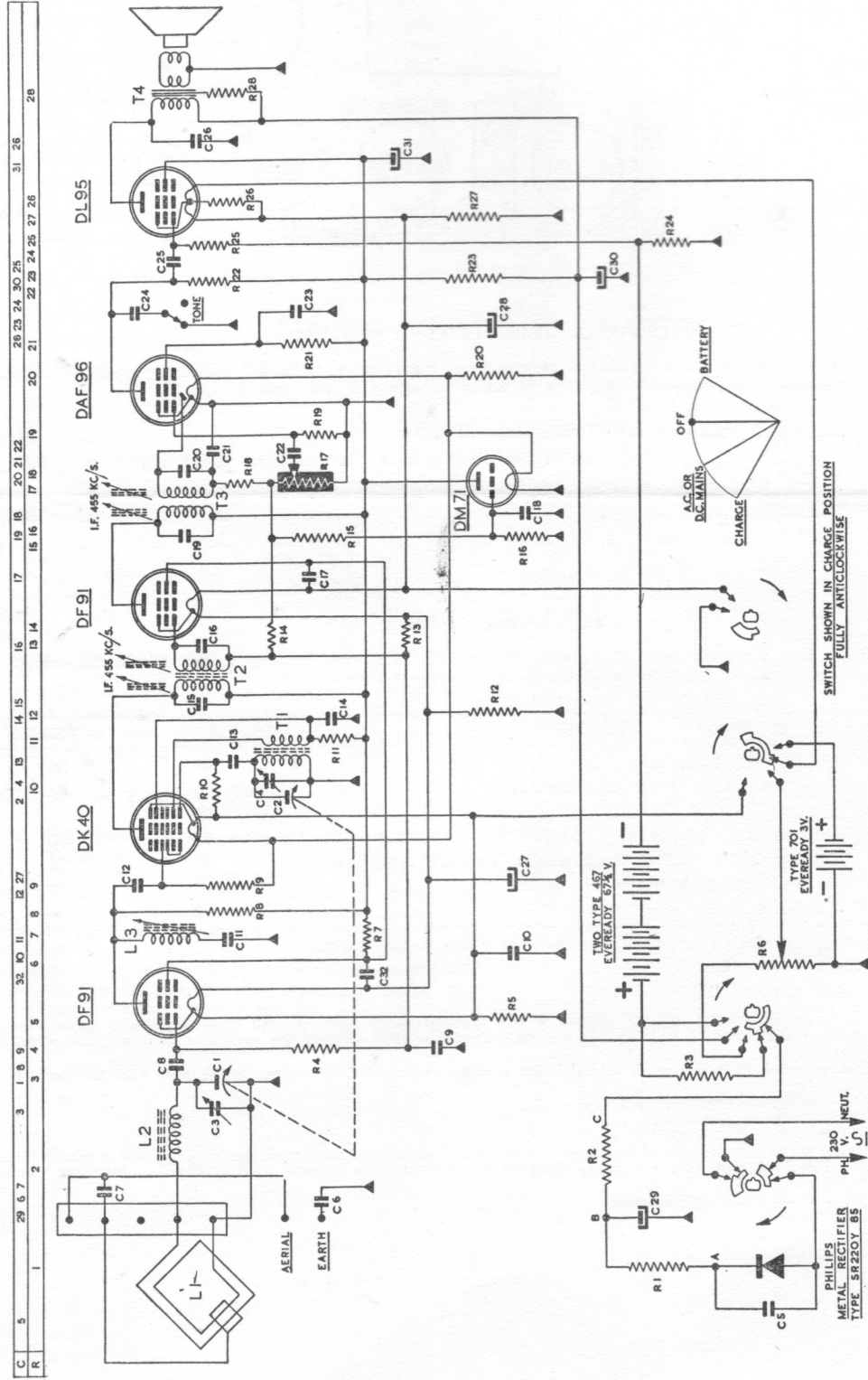

COILS

- L1 Loop aerial
- L2 Aerial coupling coil
- L3 I.F. trap
- T1 Oscillator coil
- T2 I.F. transformer
- T3 I.F. transformer
- T4 Output transformer

- A3-118-53
- VK-469-68
- VK-473-18
- VK-471-12
- A3-126-84
- A3-126-84
- VK-670-84

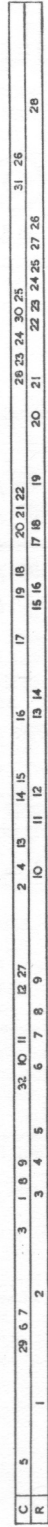

COIL AND TRANSFORMER RESISTANCES

| CODE No. | FUNCTION | WINDING | D.C. RESISTANCE |
|-----------|--------------------------------|---------|--|
| A3-118-53 | Loop aerial | L1 | 0.9 ohm |
| VK-469-68 | Aerial coupling coil | L2 | 0.85 ohm |
| VK-473-18 | I.F. trap | L3 | 22 ohms |
| VK-471-42 | Oscillator coil | T1 | { Tuned 11 ohms Feedback 5.25 ohms |
| A3-126-84 | Intermediate frequency filters | T2, T3 | { Primary 5.65 ohms Secondary 3.25 ohms |
| VK-670-84 | Output transformer | T4 | { Primary 340 ohms Secondary 0.75 ohm |

JZ 546 UB

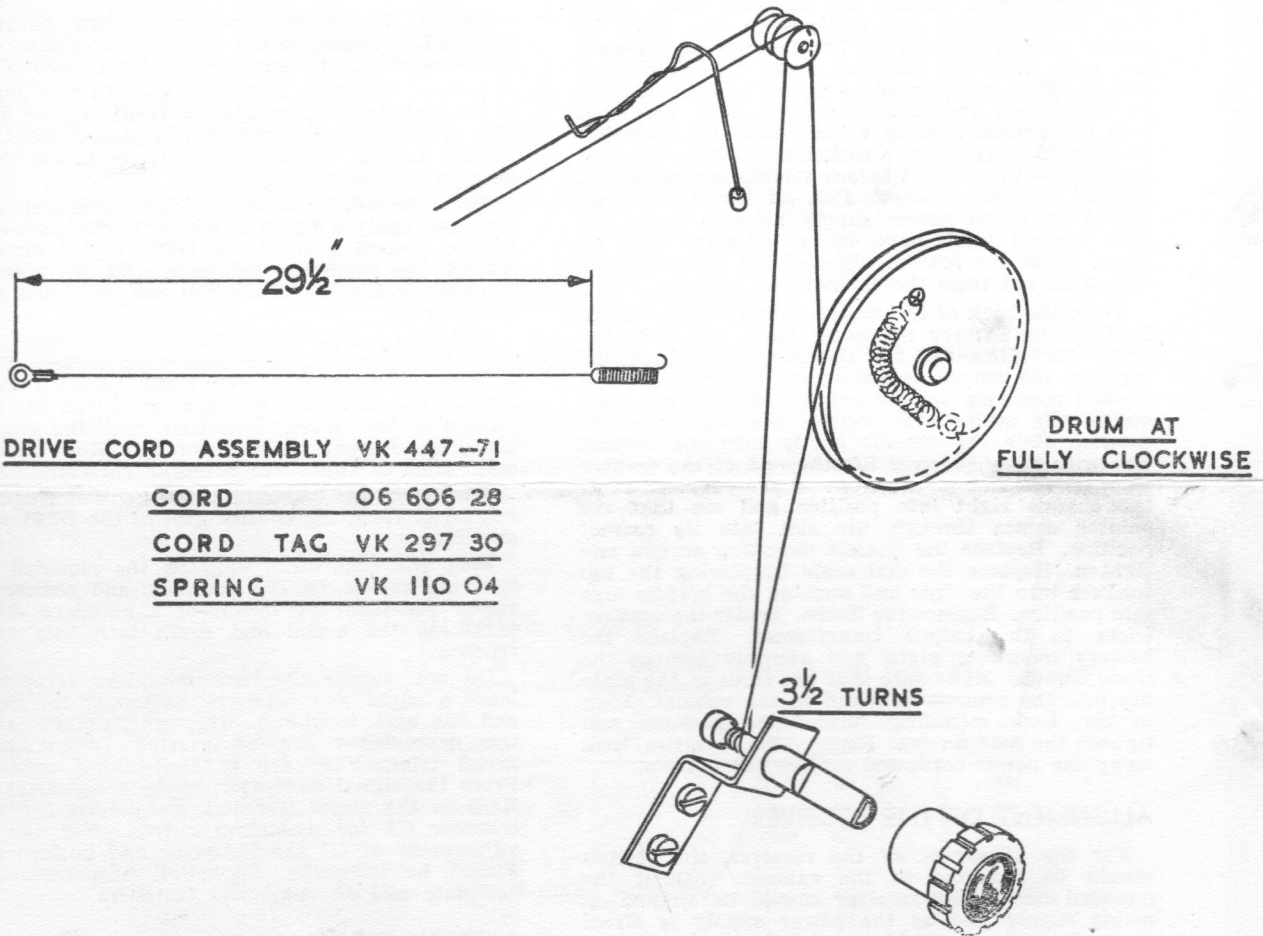

REPLACING THE TUNING CONDENSER DRIVE CORD

To replace the drive cord, remove the chassis from the cabinet. With the drum in the maximum clockwise position (maximum capacity of the tuning condenser) place the hook of the spring (VK-110-04) through the drilled hole in the drum. Feed the cord through the gap in the rim of the drum in a clockwise direction so that it comes off the drum at approximately 9 o'clock position and over the front right-hand pulley on the gantry assembly. Place the cord round the left-hand pulley, along the gantry and over the rear right-hand pulley. The cord now makes three and a half turns in a clockwise direction round the tuning spindle, progressing towards the front edge of the shaft, then meeting the drum at the 9 o'clock position, feeding on the front of the rim. Take the cord round the rim of the drum in a clockwise direction

and with a pair of pliers extend the spring until the cord can be fed through the gap in the rim, and the cord tag (VK-297-30) placed over the end of the spring.

Turn the drive shaft a few times so that the tension is equalised over the cord and adjust the turns on the drive shaft so that they do not bind on themselves or the bearings. Replace the pointer on the rear cord along the top of the gantry, by placing one and a half turns of cord round the horizontal shank of the pointer, note the direction on the drawing.

See that the gang drum is secure on the tuning condenser shaft, replace the chassis in the cabinet, and adjust the calibration by sliding the pointer along the cord.